

## INTRODUCTION

- Traditional dry powder inhaler (DPI) formulations for pulmonary delivery are binary blends, consisting of the micronized API particles blended with coarse lactose carrier particles comprising the bulk of the formulation.
- However, the inability of passive DPIs to detach the drug from the carrier particle during the patient's inspiratory maneuver results in their low efficiency, as generally < 30% of the delivered dose is sufficiently dispersed to reach the deep lung (1).
- We have previously described using low-density beads coated with pure micronized drug powder to serve as carriers from which the API is dispersed during inhalation (2).
- The aim of the present study is the development of a low-resistance passive dry powder inhaler designed to optimize the performance of Respira Therapeutics' large drug-coated carrier technology.

## MATERIALS AND METHODS

- Materials:** Micronized albuterol sulphate was purchased from Letco Medical (AL, USA), while budesonide, tiotropium bromide, salmeterol xinafoate and fluticasone propionate were obtained from Kemprotec Limited (England). Low-density, expanded polystyrene beads were generously provided by NOVA Chemicals Corporation (Canada).
- Device Design and Resistance:** A simple two-piece inhaler was designed, comprised of a lower component housing the dispersion chamber, and an upper chamber containing the powder flow channel. Flow bypass channels are located circumferentially around the mouthpiece and connected to an outer channel that surrounds the powder channel. A mesh is included downstream of the dispersion chamber to prevent bead escape during inhalation (Fig. 1). To assess the resistance of the inhaler, the pressure drop across the DPI at multiple volumetric flow rates was measured using a digital manometer. The device resistance of the prototype and several commercial inhalers was determined as described by Clark and Hollingworth (3).
- Drug Coating:** In contrast to traditional lactose formulations, where the dose is placed inside a capsule or blister, for Respira's technology the desired dose is adhered directly onto the surface of the bead via a proprietary process in the form of pure micronized drug particles. Since this process employs no coarse excipients (e.g. lactose) the micronized drug particles can adhere onto the surface of the bead via strong interparticle forces, including van der Waals forces. This process enables the drug to be stably coated onto the bead surface and remain strongly adhered from the time it is coated up until it is actuated.
- In vitro Aerosol Performance:** Aerosol performance of the drug-coated large carrier particles was evaluated in vitro with a next generation cascade impactor (NGI; MSP Corporation, MN, USA). For each actuation, a single, 5.2-mm drug-coated bead ( $\rho = 0.028$  g/cc) was placed into the dispersion chamber of the device. To assess the DPI's ability to function at moderately low inspiratory efforts, the volumetric flow rate was set to 90 L min<sup>-1</sup>, corresponding to a 2 kPa pressure drop across the inhaler. To prevent particle re-entrainment, the NGI stages were coated with a 2% (v/v) solution of silicon oil in hexane and allowed to air dry prior to each impaction. Following each impaction, the bead, dispersion chamber, mouthpiece, mouthpiece adaptor, and induction port were each rinsed with 10 mL of the respective sample solvent (water for albuterol sulphate, methanol for tiotropium bromide, and a mobile phase of 75:25 mixture of methanol and 0.8% (w/v) ammonium acetate buffer (pH = 5.5) for fluticasone and salmeterol); the stages of the NGI were each rinsed with 5 mL. The drug content of albuterol sulphate was assayed by UV-VIS spectroscopy at 230 nm, while tiotropium bromide was measured at 238 nm. Fluticasone propionate and salmeterol xinafoate were assayed by HPLC according to a published protocol (4). The fine particle fraction (FPF) is provided as the percentage of the delivered dose depositing below stage 1, corresponding to particles with aerodynamic diameters < 6.48  $\mu$ m.

## RESULTS AND DISCUSSION

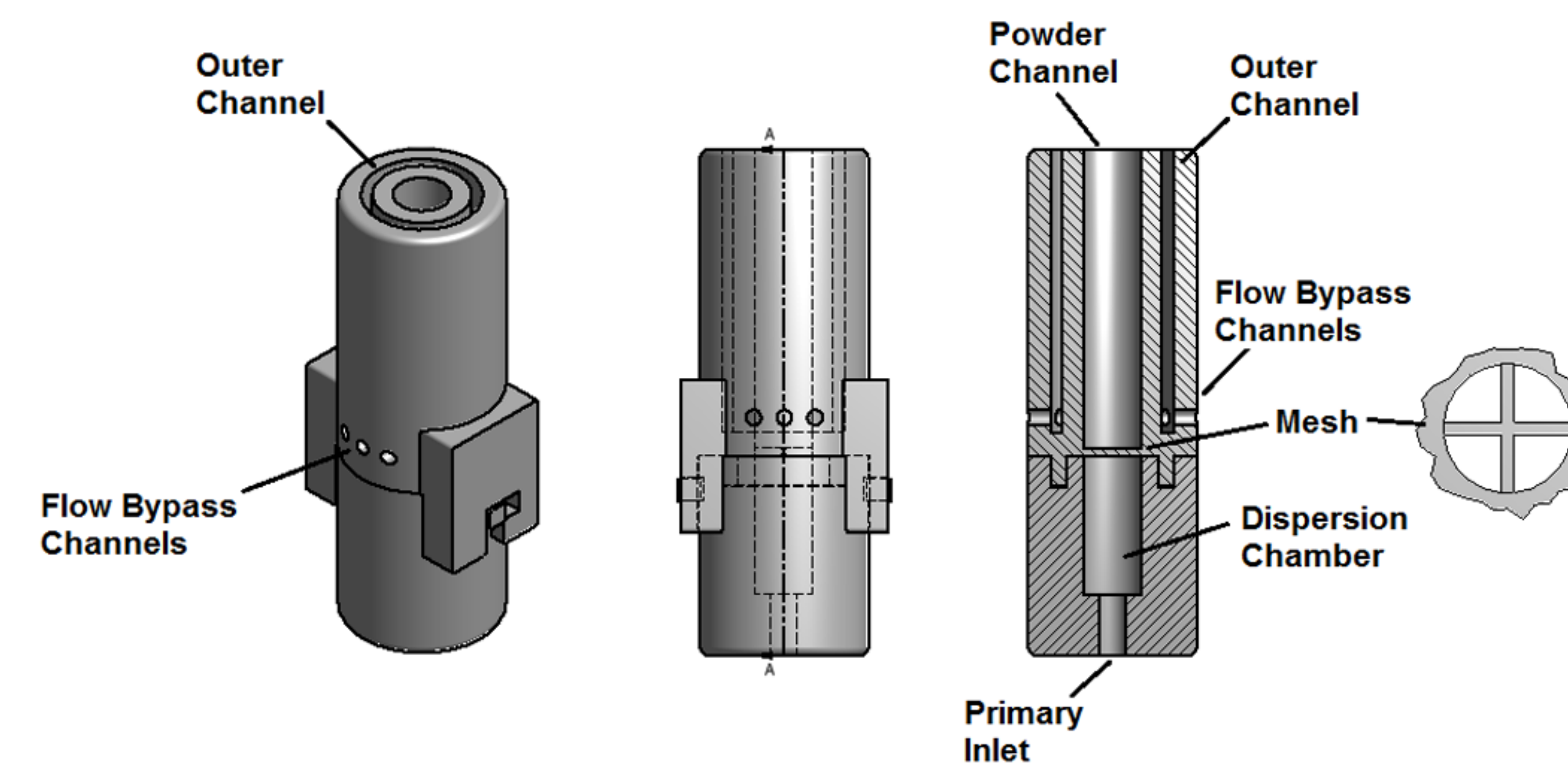

Fig. 1. Simplified diagram of Respira's prototype DPI indicating the major device components.

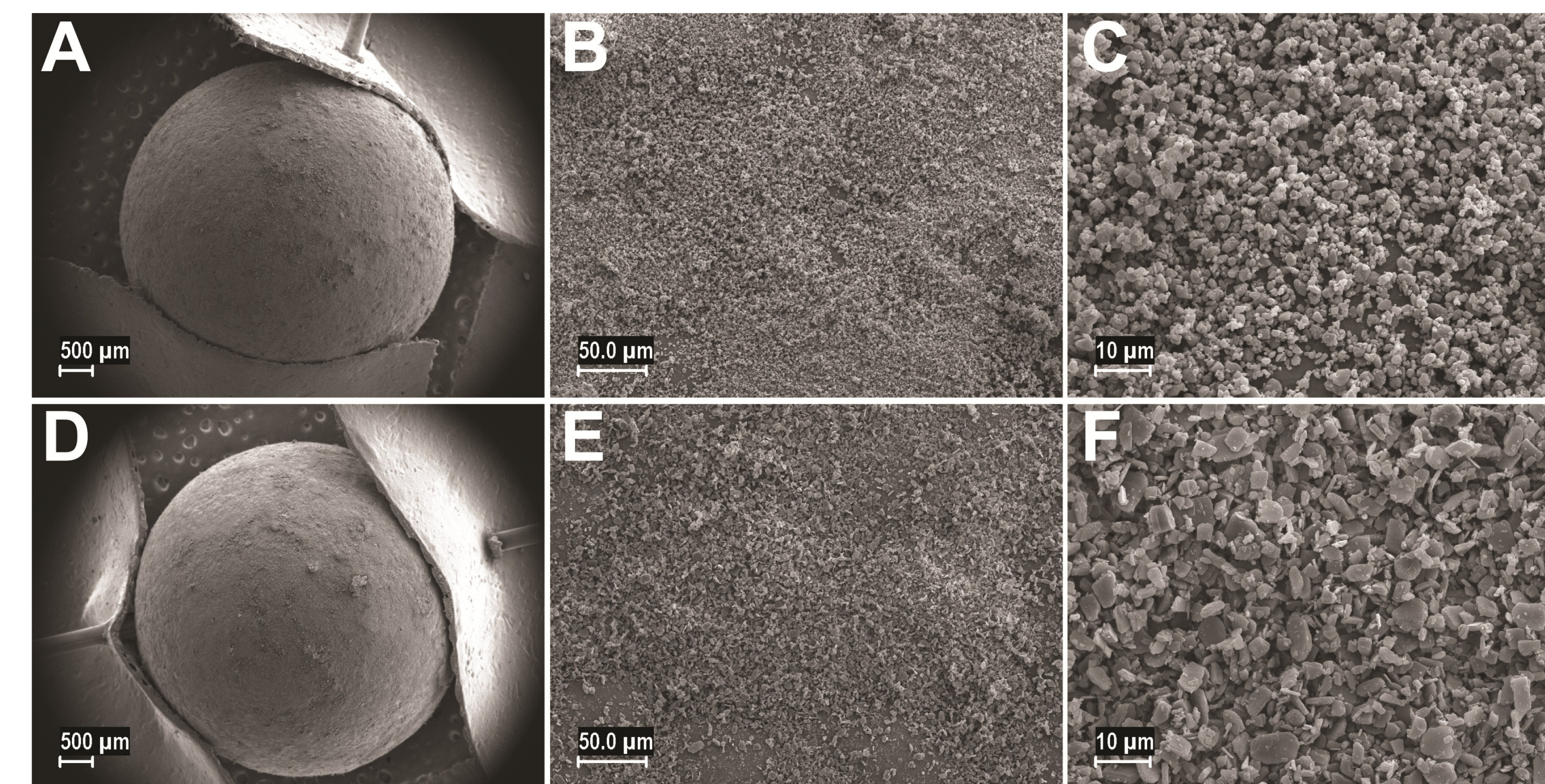

Fig 2. SEM images depicting budesonide (A – C, and albuterol (D – F) coated beads. Scale bars denote 500  $\mu$ m (A, D), 50  $\mu$ m (B, E) and 10  $\mu$ m (C, F).

API	Nominal Dose (mcg)	FPF (%)
Budesonide	215	83 (2%)
Fluticasone Propionate	112	81 (2%)
Albuterol Sulphate	81	91 (2%)
Salmeterol Xinafoate	36	89 (3%)
Tiotropium Bromide	20	85 (2%)

Table 1. In vitro aerosol performance of multiple drug types at 90 L min<sup>-1</sup>, corresponding to a 2 kPa pressure drop across the inhaler. FPF represents the fine particle fraction of the emitted dose. Data is provided as the mean ( $\pm$  standard deviation) for N = 3 replicates.

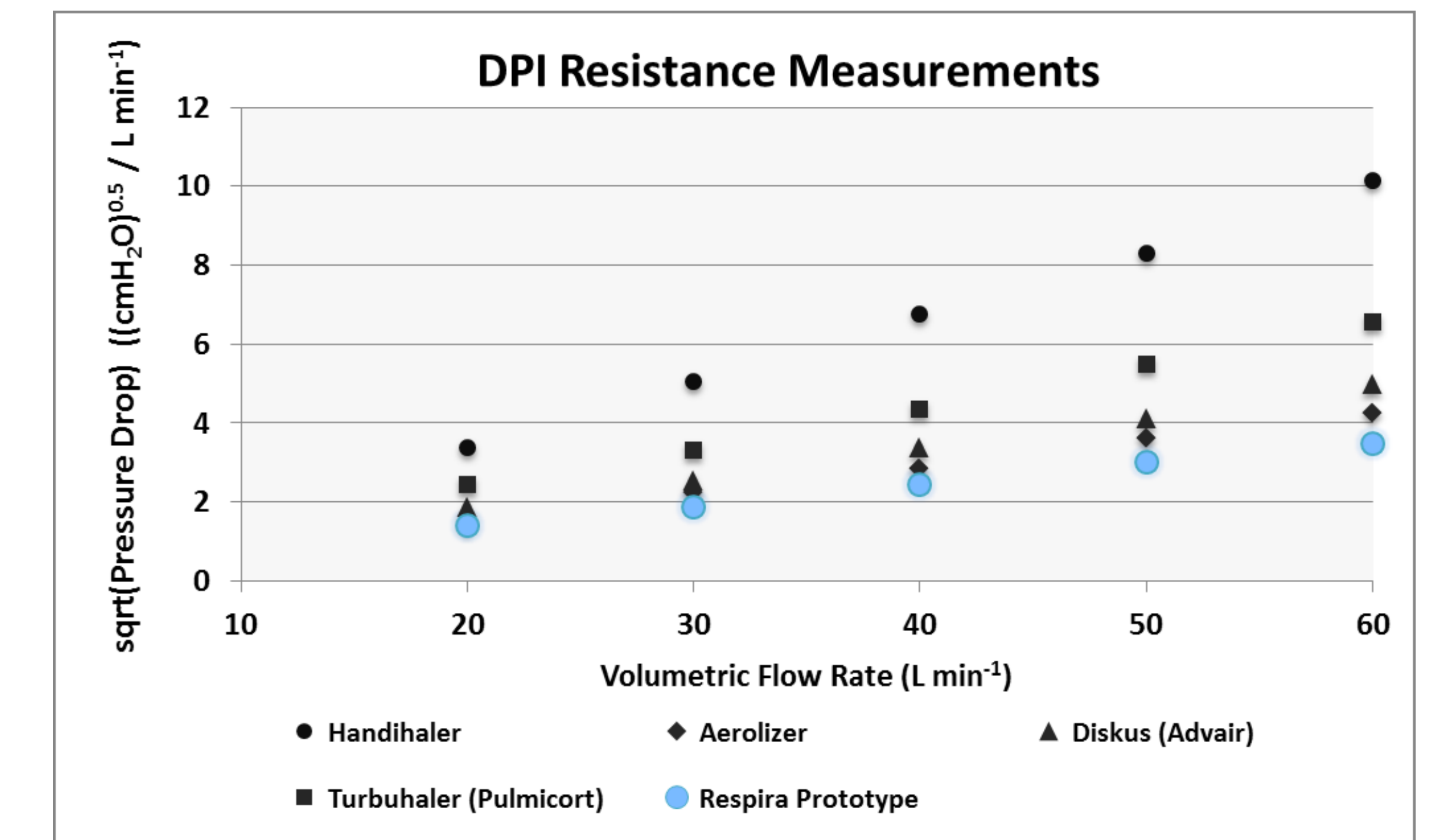

Fig. 3. Measured device resistances of commercial inhalers and DPI prototype

- The measured resistance of the DPI was 0.048 (cmH<sub>2</sub>O)<sup>0.5</sup> / L min<sup>-1</sup>, with a 4 kPa and 2 kPa pressure drop across the device corresponding to 128 L min<sup>-1</sup> and 90 L min<sup>-1</sup>, respectively, indicating a low resistance inhaler (5). The resistance of the prototype was less than the measured values of several commercial devices (Fig. 3).
- The coating process employed to adhere the drug onto the bead surface disrupts large drug particle agglomerates (Fig. 2). This enables the drug particles to detach from the bead surface largely in their primary particle size, producing excellent deposition profiles across a broad range of prescribed therapeutics agents (Table 1).

## CONCLUSIONS

- The inhaler designed in this study possessed a very low resistance, yet was characterized by highly efficient delivery across a broad dosing range for multiple APIs.
- The detachment forces generated via the rapid oscillations of the bead within the dispersion chamber were sufficient to emit a high percentage (> 85%) of the nominal dose from the device.

## ACKNOWLEDGEMENTS

- We acknowledge the TherapeUTex Preclinical Core at the University of Texas, College of Pharmacy for their assistance with the HPLC analyses.

## REFERENCES

- Steckel, H, and Muller, B.W. (1997), *Int. J. Pharm.*, 154, 19 – 29
- Donovan MJ and Smyth HDC (2010), *Drug Delivery to the Lungs 21*
- Clark, A.R., and Hollingworth, A.M. (1993), *J. Aero. Med.*, 6 (2), 99 - 110
- Taki, M., et al. (2010), *Int. J. Pharm.*, 388, 40 – 51
- Dunbar, C.A., et al. (2000), *PDA J. Pharm. Sci. & Tech.*, 54 (6), 478 - 484